

NPD12-134Ah 12V134Ah

Valve Regulated Lead Acid Battery



● Specifications

Nominal voltage	12V (6 cells per unit)	
Rated capacity (10HR)	134Ah/10.8V	
Dimensions	Length	342±2mm (13.46inch)
	Width	172±2mm (6.77inch)
	Height	280±2mm (11.02inch)
	Total height	285±2mm (11.20inch)
Approx. weight	44.00kg (97.00lbs)±3%	

● Outer dimensions (mm)

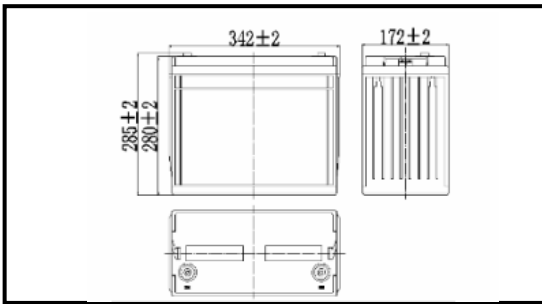

● Terminal type (mm)

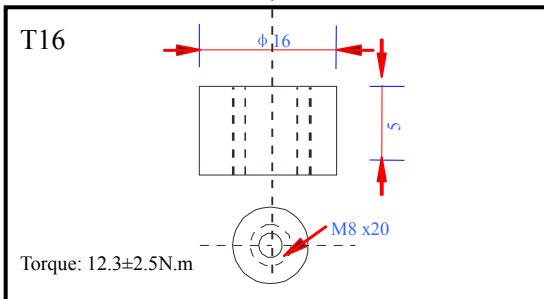

● Characteristics

Capacity (25°C)	10HR (10.8V)	134Ah
	3HR (10.8V)	105Ah
	1HR (10.5V)	78Ah
Terminal type		T16
Internal resistance (Fully charged, 25°C)		Approx. 3.8mΩ
Capacity affected by temperature (10HR)	40°C	102%
	25°C	100%
	0°C	85%
	-15°C	65%
Self-discharge (25°C)	3 months	Remaining capacity: 91%
	6 months	Remaining capacity: 82%
	12 months	Remaining capacity: 65%
Nominal operating temperature		25°C±3°C (77°F±5°F)
Operating temperature range	Discharge	-15°C~50°C (5°F~122°F)
	Charge	-10°C~50°C (14°F~122°F)
	Storage	-20°C~50°C (-4°F~122°F)
Float charging voltage (25°C)		13.50 to 13.80V Temperature compensation: -18mV/°C/Block
Cyclic charging voltage (25°C)		14.50 to 15.00V Temperature compensation: -30mV/°C/Block
Maximum charging current		42A
Maximum discharge current		1050A (5 sec.)
Design life	10 years for floating (25°C)	
	Eurobat (20°C): 10/12 years, long life.	

● Construction

Component	Positive plate	Negative plate	Container	Cover	Separator	Electrolyte	Safety valve	Terminal
Raw material	Lead dioxide	Lead	ABS	ABS	AGM	Sulfuric acid	Rubber	Copper

● Constant current discharge characteristics unit: Ampere/Block (at 25°C, 77°F)

F.V/Time	10min	15min	30min	60min	2h	3h	4h	5h	8h	10h	20h
9.60V	305	235	141	86.5	51.2	36.8	29.4	25.1	17.3	14.3	7.55
9.90V	296	230	138	85.2	50.9	36.6	29.2	25	17.2	14.2	7.54
10.2V	284	221	134	83.1	50.4	36.4	29	24.8	17.1	14.2	7.52
10.5V	272	214	130	80.5	49.6	36.1	28.8	24.6	16.9	14.1	7.47
10.8V	256	202	126	77.9	48.4	35	28	23.9	16.4	14	7.42

● Constant power discharge characteristics unit: Watt/Block (at 25°C, 77°F)

F.V/Time	10min	15min	30min	60min	2h	3h	4h	5h	8h	10h	20h
9.60V	3296	2582	1579	986	592	433	346	297	205	170	90.6
9.90V	3197	2521	1547	972	589	431	344	295	204	170	90.5
10.2V	3065	2428	1500	947	584	428	342	293	203	169	90.2
10.5V	2934	2345	1463	917	575	425	339	291	201	168	89.7
10.8V	2769	2221	1410	888	560	412	329	283	195	167	89.0

Note 1: Above characteristics data can be obtained within three charge and discharge cycles.

● Discharge characteristics (25°C)

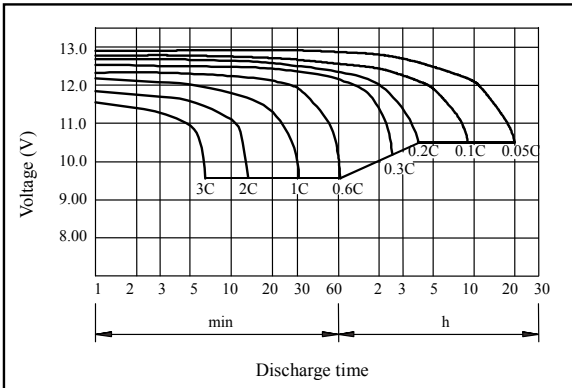

● Charging characteristics (25°C)

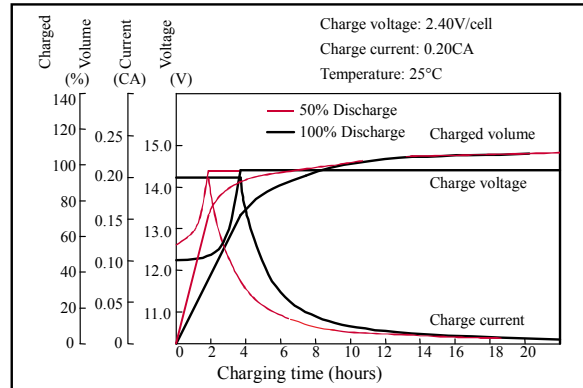

● Temperature effects on capacity

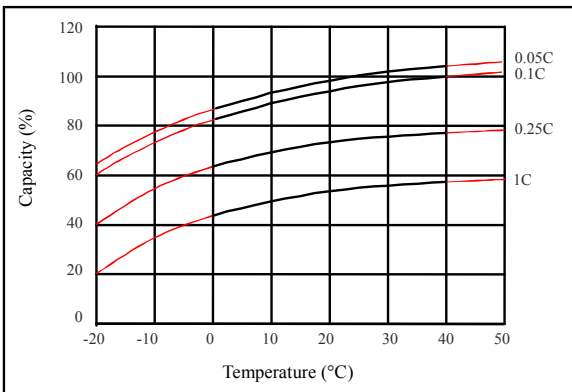

● Self-discharge characteristics

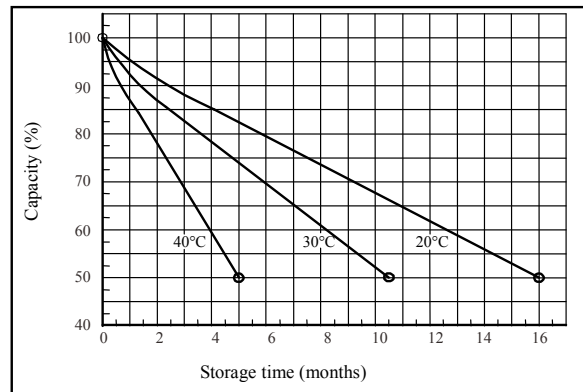

● Floating life on temperature

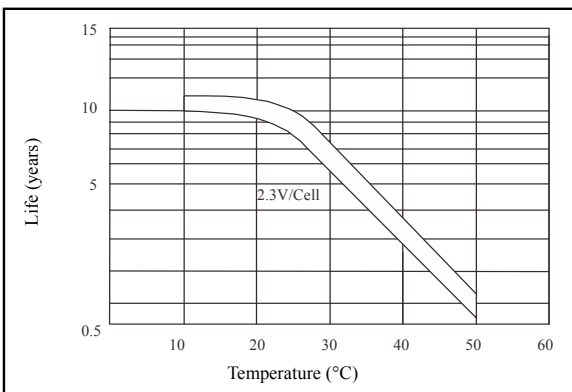

● Cycle life on D.O.D (25°C)

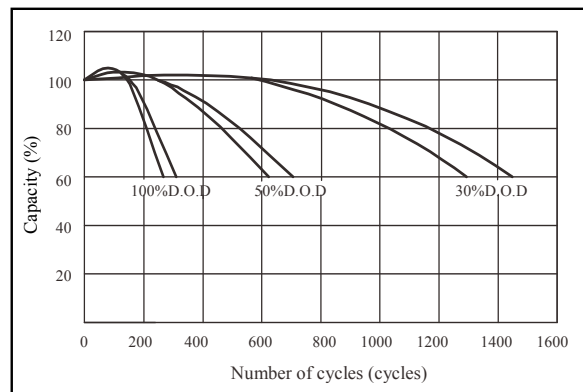

● Relationship for OCV and capacity (25°C)

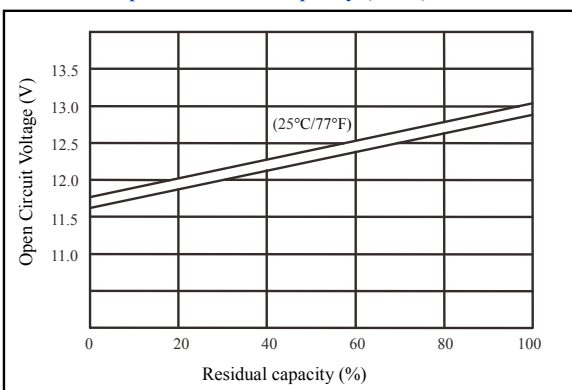

● Relationship for charging voltage and temperature

