

NPG6-200Ah 6V200Ah

Valve Regulated Lead Acid Battery



Specifications

Nominal voltage	6V (3 cells per unit)	
Rated capacity (10HR)	200Ah/5.4V	
Dimensions	Length	322±2mm (12.68inch)
	Width	178±2mm (7.01inch)
	Height	227±2mm (8.94inch)
	Total height	230±2mm (9.06inch)
Approx. weight	30.50kg (67.20lbs)±3%	

Outer dimensions (mm)

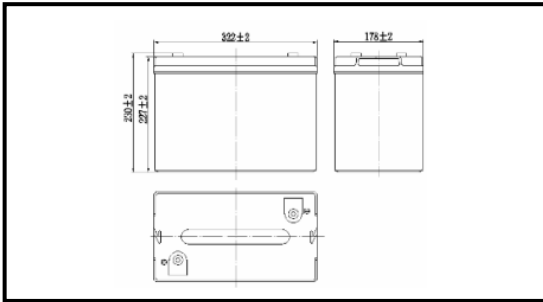

Terminal type (mm)

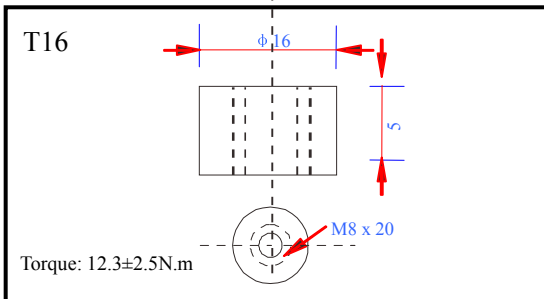

Characteristics

Capacity (25°C)	10HR (5.4V)	200Ah
	3HR (5.4V)	150Ah
	1HR (5.25V)	110Ah
Terminal type		T16
Internal resistance (Fully charged, 25°C)		Approx. 2mΩ
Capacity affected by temperature (10HR)	40°C	102%
	25°C	100%
	0°C	85%
	-15°C	65%
Self-discharge (25°C)	3 months	Remaining capacity: 91%
	6 months	Remaining capacity: 82%
	12 months	Remaining capacity: 65%
Nominal operating temperature		25°C±3°C (77°F±5°F)
Operating temperature range	Discharge	-15°C~50°C (5°F~122°F)
	Charge	-10°C~50°C (14°F~122°F)
	Storage	-20°C~50°C (-4°F~122°F)
Float charging voltage (25°C)		6.75 to 6.90V Temperature compensation: -9mV/°C/Block
Cyclic charging voltage (25°C)		7.20 to 7.35V Temperature compensation: -15mV/°C/Block
Maximum charging current		40A
Maximum discharge current		1400A (5 sec.)
Design life	12 years for floating (25°C)	
	Eurobat (20°C):10/12 years, long life.	

Construction

Component	Positive plate	Negative plate	Container	Cover	Separator	Electrolyte	Safety valve	Terminal
Raw material	Lead dioxide	Lead	ABS	ABS	AGM	Gel	Rubber	Copper

Constant current discharge characteristics unit: Ampere/Block (at 25°C, 77°F)

F.V/Time	10min	15min	30min	60min	2h	3h	4h	5h	8h	10h	20h
4.80V	390	320	194	120	73.1	52.0	40.8	34.7	24.5	20.4	10.8
4.95V	378	312	190	118	72.6	51.7	40.6	34.5	24.3	20.3	10.8
5.10V	363	301	184	115	72.0	51.4	40.3	34.2	24.2	20.3	10.7
5.25V	347	291	180	112	70.9	51.0	40.0	34.0	24.0	20.1	10.7
5.40V	328	275	173	108	69.1	50.0	38.8	33.0	23.3	20.0	10.6

Constant power discharge characteristics unit: Watt/Block (at 25°C, 77°F)

F.V/Time	10min	15min	30min	60min	2h	3h	4h	5h	8h	10h	20h
4.80V	2106	1757	1088	684	423	306	240	205	145	122	64.7
4.95V	2043	1715	1067	674	421	304	238	204	145	121	64.6
5.10V	1959	1651	1034	657	417	302	237	202	144	121	64.4
5.25V	1874	1595	1009	636	411	300	235	201	143	120	64.0
5.40V	1769	1511	972	616	400	294	228	195	138	119	63.6

Note 1: Above characteristics data can be obtained within three charge and discharge cycles.

● Discharge characteristics (25°C)

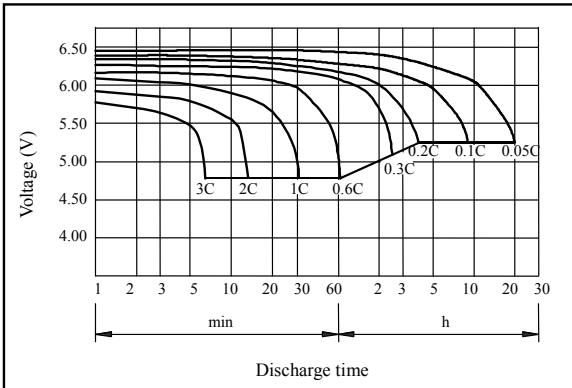

● Charging characteristics (25°C)

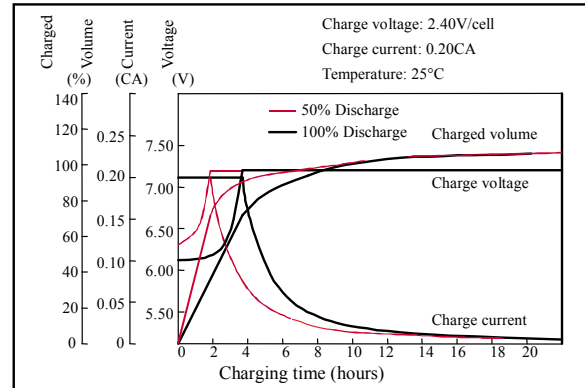

● Temperature effects on capacity

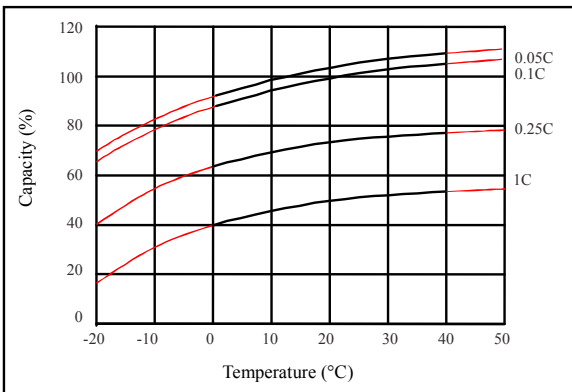

● Self-discharge characteristics

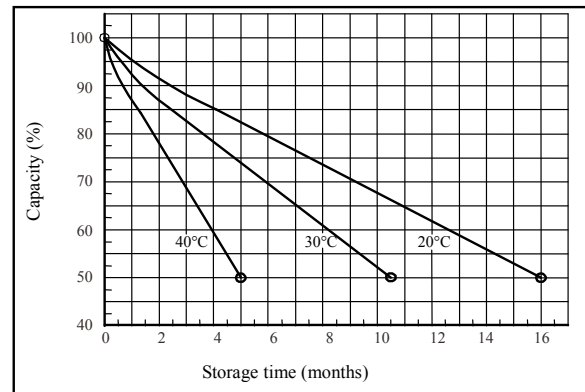

● Floating life on temperature

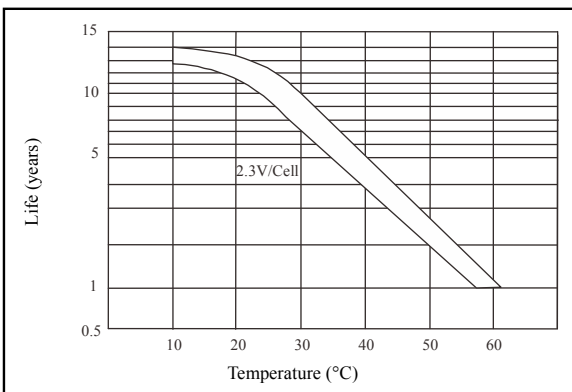

● Cycle life on D.O.D (25°C)

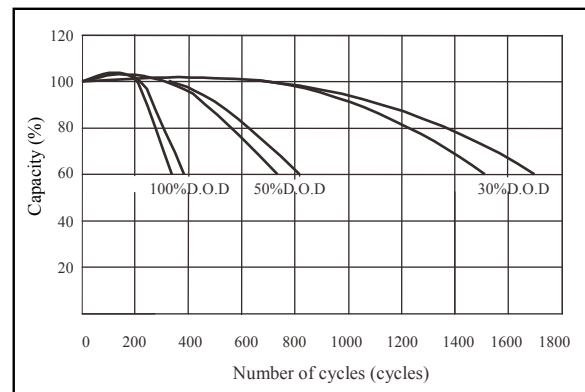

● Relationship for OCV and capacity (25°C)

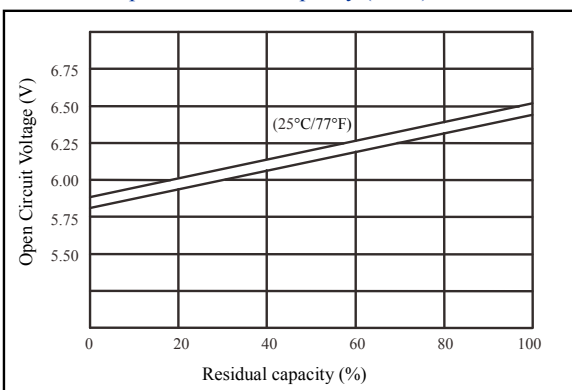

● Relationship for charging voltage and temperature

