

FT12-50Ah 12V50Ah

Valve Regulated Lead Acid Battery



Specifications

Nominal voltage	12V (6 cells per unit)	
Rated capacity (10HR)	50Ah/10.8V	
Dimensions	Length	277±2mm (10.91inch)
	Width	106±2mm (4.17inch)
	Height	221±2mm (8.70inch)
	Total height	221±2mm (8.70inch)
Approx. weight	16.00kg (35.30lbs)±3%	

Outer dimensions (mm)

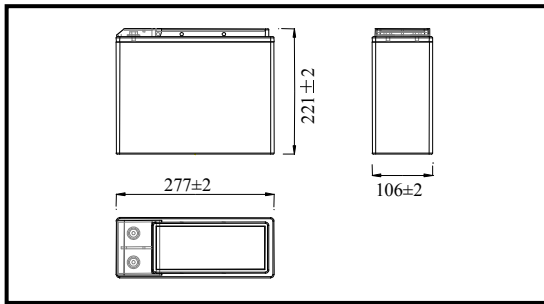

Terminal type (mm)

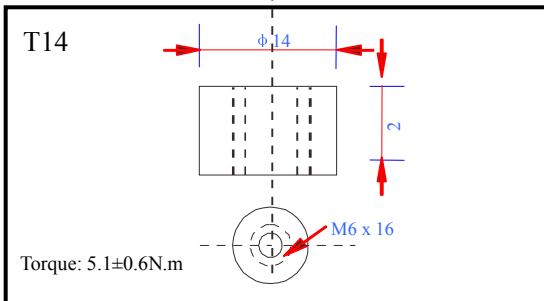

Characteristics

Capacity (25°C)	10HR (10.8V)	50Ah
	3HR (10.8V)	37.5Ah
	1HR (10.5V)	27.5Ah
Terminal type		T14
Internal resistance (Fully charged, 25°C)		Approx. 7.5mΩ
Capacity affected by temperature (10HR)	40°C	102%
	25°C	100%
	0°C	85%
	-15°C	65%
Self-discharge (25°C)	3 months	Remaining capacity: 91%
	6 months	Remaining capacity: 82%
	12 months	Remaining capacity: 65%
Nominal operating temperature		25°C±3°C (77°F±5°F)
Operating temperature range	Discharge	-15°C~50°C (5°F~122°F)
	Charge	-10°C~50°C (14°F~122°F)
	Storage	-20°C~50°C (-4°F~122°F)
Float charging voltage (25°C)		13.50 to 13.80V Temperature compensation: -18mV/°C/Block
Cyclic charging voltage (25°C)		14.50 to 15.00V Temperature compensation: -30mV/°C/Block
Maximum charging current		15A
Maximum discharge current		400A (5 sec.)
Design life	12 years for floating (25°C)	
	Eurobat (20°C): 10-12 years, long life.	

Construction

Component	Positive plate	Negative plate	Container	Cover	Separator	Electrolyte	Safety valve	Terminal
Raw material	Lead dioxide	Lead	ABS	ABS	AGM	Sulfuric acid	Rubber	Copper

Constant current discharge characteristics unit: Ampere/Block (at 25°C, 77°F)

F.V/Time	10min	15min	30min	60min	2h	3h	4h	5h	8h	10h	20h
9.60V	107	82.3	49.2	30.3	18.3	13.2	10.5	8.98	6.17	5.09	2.70
9.90V	104	80.3	48.3	29.8	18.2	13.1	10.4	8.92	6.13	5.08	2.69
10.2V	99.3	77.4	46.8	29.1	18.0	13.0	10.4	8.86	6.09	5.07	2.68
10.5V	95.1	74.7	45.7	28.2	17.7	12.9	10.3	8.80	6.05	5.04	2.67
10.8V	89.7	70.8	44.0	27.3	17.3	12.5	10.0	8.54	5.87	5.00	2.65

Constant power discharge characteristics unit: Watt/Block (at 25°C, 77°F)

F.V/Time	10min	15min	30min	60min	2h	3h	4h	5h	8h	10h	20h
9.60V	1154	904	553	345	212	155	124	106	73.3	60.8	32.4
9.90V	1119	882	541	340	210	154	123	105	72.9	60.7	32.2
10.2V	1073	850	525	331	208	153	122	105	72.4	60.5	32.2
10.5V	1027	821	512	321	205	152	121	104	71.9	60.1	30.0
10.8V	969	777	493	311	200	147	117	101	69.7	59.7	31.8

Note 1: Above characteristics data can be obtained within three charge and discharge cycles.

● Discharge characteristics (25°C)

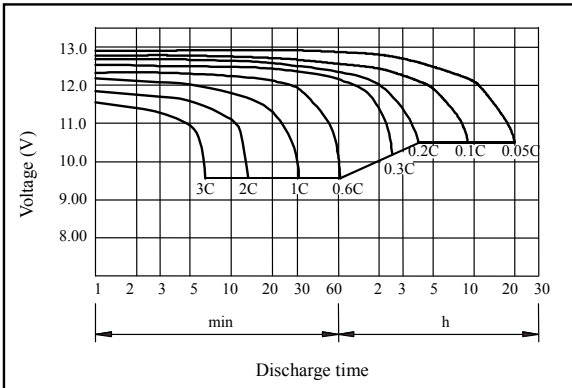

● Charging characteristics (25°C)

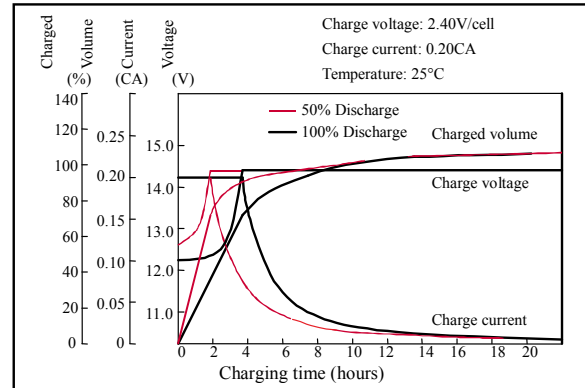

● Temperature effects on capacity

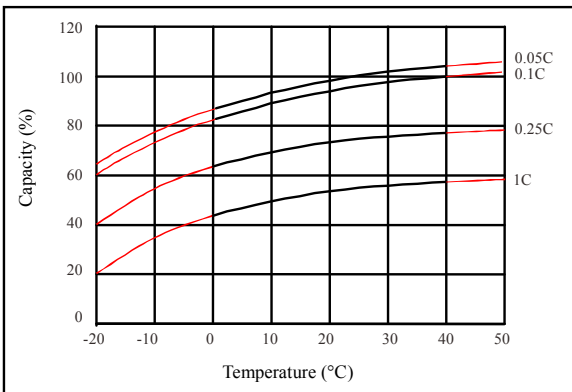

● Self-discharge characteristics

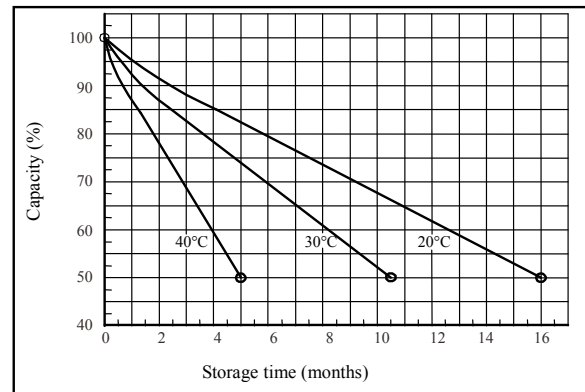

● Floating life on temperature

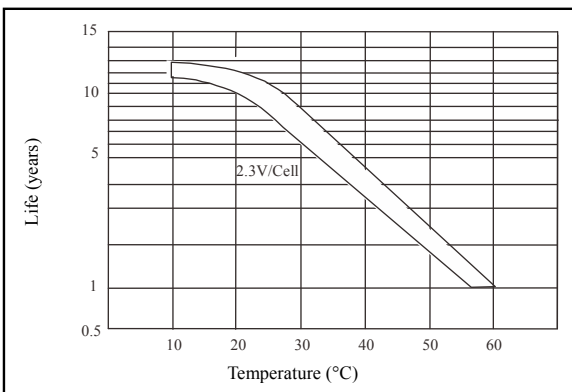

● Cycle life on D.O.D (25°C)

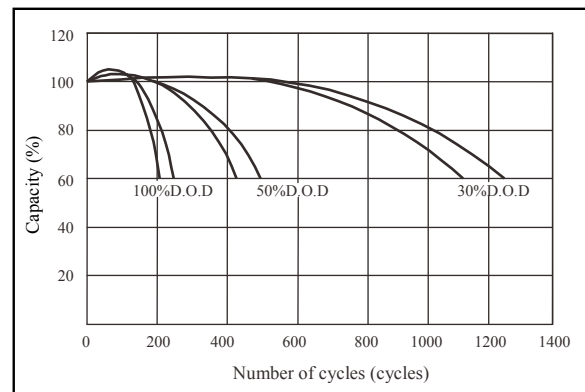

● Relationship for OCV and capacity (25°C)

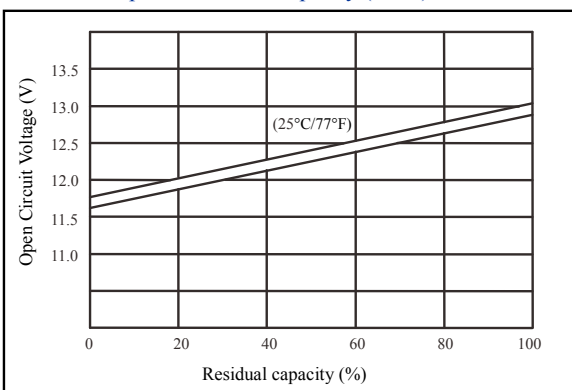

● Relationship for charging voltage and temperature

